



User Manual for WA-EUS - 720 / 730  
Ultrasonic Leak Detector

# Compressed Air Energy Saving Solutions

Smart Measurement Technology That You Can Trust



For More Info  
**SCAN HERE**

## About Us

At WiseAir Technologies, our mission is to empower industries with innovative and advanced measurement solutions for compressed air and gases. With over 20 years of expertise in the field of compressed air management, we have developed smart, reliable, and state-of-the-art products that are both accurate and easy to use. Our focus is on incorporating cutting-edge technologies like M2M communication and the Industrial Internet of Things (IIoT) to bring increased automation, improved communication, and self-monitoring to industrial processes.

Our WA range of smart IIoT sensors can be easily integrated into existing manufacturing and energy management software to enhance data collection, exchange, and analysis for improved productivity and efficiency.

## Our Network

Our Smart Sensors are Developed with Design and Technology Support from Our Partners Across North America, Europe and Asia. With Our Strong Network of Partners, we offer Seamless and Best-in-Class Service to Our Customers.



### Artificial Intelligence and Machine Learning Software

Our software are programmed to analysis and self Diagnose the Measured Datas



### Smart IIoT Sensors

For measurement of Flow, Power, Dew Point and Pressure



### Product Experts

Product Specialists with Decades of Experience in Compressed Air Measurement and Management

## Simplify Your Compressed Air Management With Our Smart Technology

Compressed Air Systems are Dynamic and Highly In-Efficient. Hence they Require Continuous Monitoring for Sustained Benefits. With Our WiseAir 4.0 Smart Sensors and M2M / AI Softwares Your Compressed Air System is Measured, Analysed and Improved Over Time.

With Our Seamless and Detailed Analytical Reports You Can Keep Track Of Your Compressed Air Systems Efficiency with Minimal Human Intervention.

## Our Services

We Offer Free Assessment Services to Identify the HotSpots For Improvements and Develop Road Maps for Sustainable Results. Our Product Specialists Can Also Offer You Customised Plans for Monitoring the Key Performance Factors Of Your Compressed Air System.

**Connect with Our Expert Product Specialists to Learn How Your Factory Can Begin to Realize Energy and Cost Savings with Our Advanced Solutions.**

#### Call Us

Asia : **+91 90477 78715**  
Europe : **+45 36 99 04 22**

#### Email Us

Asia : **info@wiseair.asia**  
Europe : **info@wiseair.asia**

## Understand The True Costs Of Compressed Air

In a Compressor's Life Cycle More than 80 % of its Operating Costs is Spent Towards its Energy. Hence Monitoring and Managing Compressors at their Peak Energy Efficiency will give Significant Energy Savings.

Our Smart Sensors Can Provide Vital Informations Like Flow, Power, Dew Point and Pressure. When Our Sensors are Networked with Our AI Software Programs, All the Measured Datas are Analysed and Reported To You With Suggested Action Plans in Real Time.

Manage Your Compressed Air System Efficiently and Effortlessly With Our WiseAir Smart Sensors and AI Softwares.

### Energy Costs



### Capital Costs



### Maintenance Costs









## Index

1_ Precautions and Safety Measures	4
2_ Introduction	5
3_ Kit Components	5
4_ Main Applications	7
5_ Maintenance	8
6_ Specifications	10
7_ Need help?	10

## Precautions And Safety Measures

### Symbols

	Caution! Refer to the explanation in this manual.
	Consult user documentation.
	Battery.
	Complies with European Directives.
	Conforms to relevant South Korean EMC Standards. Electromagnetic Compatibility: Korea (KCC): Class A Equipment (Industrial Broadcasting & Communication Equipment)[ <sup>1</sup> ] [ <sup>1</sup> ]This product meets requirements for industrial (Class A) electromagnetic wave equipment and the seller or user should take notice of it. This equipment is intended for use in business environments and is not to be used in homes.
	Conforms to relevant Australian standards.
	This product complies with the WEEE Directive marking requirements. The affixed label indicates that you must not discard this electrical/electronic product in domestic household waste. Product Category: With reference to the equipment types in the WEEE Directive Annex I, this product is classed as category 9 "Monitoring and Control Instrumentation" product. Do not dispose of this product as unsorted municipal waste.

### Safety Information

- The product complies with :
  - IEC 61326-1

### WARNINGS AND PRECAUTIONS:

- Not for use on explosive gases.
- Use extreme care when using near pressurized air/gas.
- Use extreme care when using near rotation equipment.
- Use extreme care when using near electrical equipment.

### CENELEC Directives

- The instrument conforms to CENELEC Electromagnetic compatibility directive 2014/30/EU.
- Use only 4 x AA batteries for the EUS-720-R Receiver and only 2 x AAA size batteries for the EUS-720-T Transmitter, properly installed in the battery compartment, to power the Product (see Section 5: Maintenance).
- Remove the batteries if the Product is not used for an extended period of time, or if stored in temperatures above 122 °F (50 °C). If the batteries are not removed, battery leakage can damage the Product.
- Follow all battery care from the battery manufacturer.

## Introduction

- Ultrasonic sound, or ultrasound, is a sound wave with frequencies above 20 kHz, higher than the upper audible limit of human hearing. Ultrasound can be generated when turbulence created by air or gas is forced through a small orifice. Leaking air or gas is generally considered to be viscous flow, and as the flow velocity increases, the frequency of the ultrasound emitted becomes higher. Vibrating, moving objects or electric discharge will also create an ultrasonic wave, which is very directional in nature and can be used to pinpoint the exact location of a leak, vibration or discharge.
- The EUS-720-R Receiver detects ultrasounds within 20 kHz to 90 kHz frequency, then amplifies and converts these ultrasonic sounds to frequencies and levels that the human ear can hear through headphones and show it on the LCD screen. The 20 kHz to 90 kHz frequency range is the optimal range for detecting a variety of leakage events in assets such as HVAC systems and pneumatic lines. A change in the ultrasound produced by an asset may be indicative that an asset is beginning to fail.



Figure 2: Sound range spectrum

## Kit Components

- Your Shipping Box should include :

	WA-EUS-720	WA-EUS-730
Receiver	1	1
Transmitter	-	1
Headphones	1	1
Earbuds (for use with hard hat)	1	1
Power Parabola	1	1
Flexible Probe	1	1
Probe Extension	1	1
Hard Carrying Case	1	1
User Manual	1	1
AA Batteries (Receiver)	Not Included	
AAA Batteries (Transmitter)	Not Included	

**Note :** Batteries are not pre-installed in the Receiver or Transmitter

● **EUS-720-R Receiver**

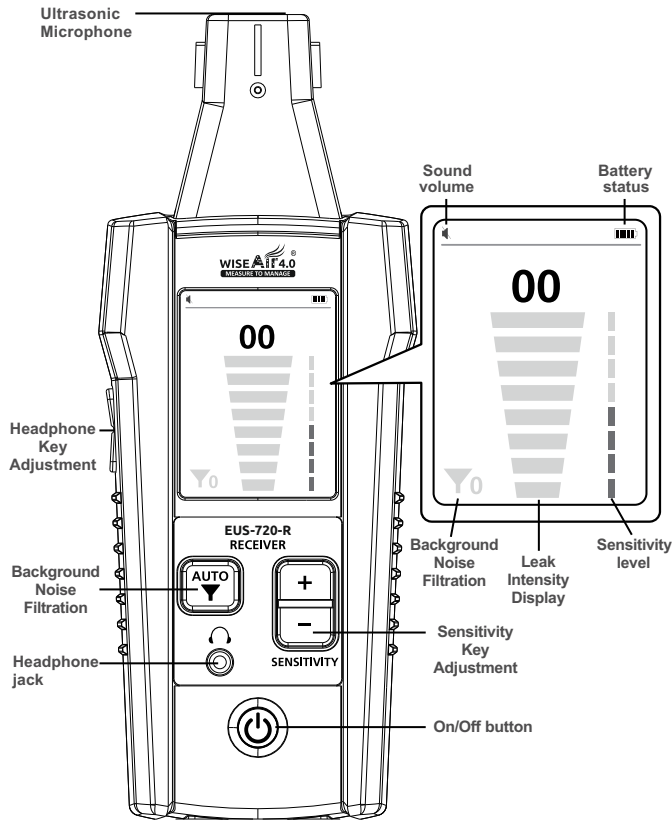

Figure 3.2: EUS-720-R Receiver

● **EUS-730-T Transmitter**

The EUS-720-T Transmitter is included with the EUS-730 kit and is optional for the EUS-720 kit.

● When a leak is not pressurized sufficiently the Receiver will not be able to detect it. In these circumstances, the EUS-720-T Transmitter can be used to emit an ultrasonic sound that the Receiver can read. The Transmitter is programmed with three signal levels for precise pinpointing of leaks.

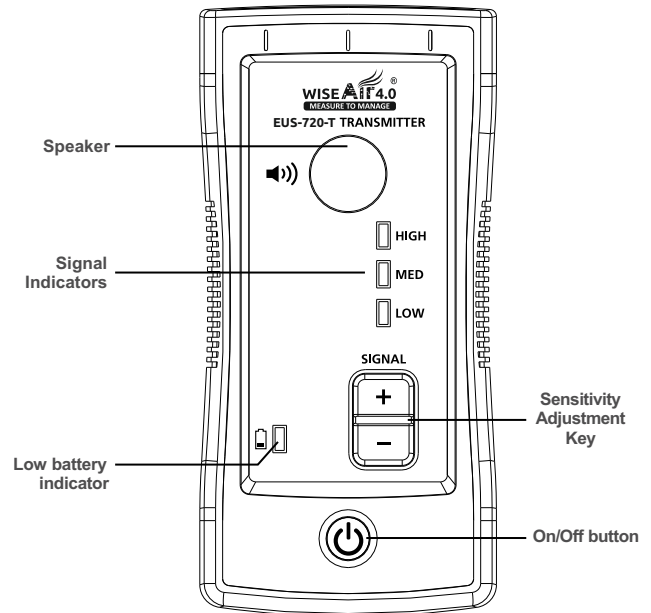

Figure 3.3: EUS-730-T Transmitter

● **Accessories**

The EUS-720 comes supplied with additional Receiver accessories that are helpful in leak identification. Plug the headphones into the Receiver to audibly hear the leak and verify its source (for example hissing sound of an air leak versus ticking sound of an electric discharge). Use the Parabola attachment in situations where there is a high level of background noise to help direct the ultrasound towards the sensor. Use the Tubular Extension with the Adapter in hard to reach areas for additional reach.

**Note: There is no speaker on the Receiver. Without headphones, no noise will be audible.**

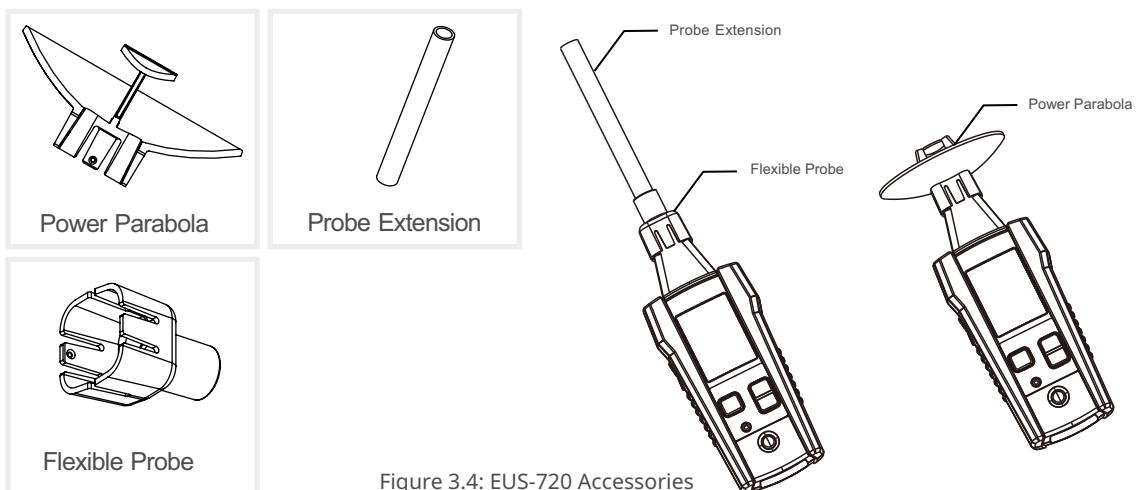

Figure 3.4: EUS-720 Accessories

## Main Applications

### Using the EUS-720-R Ultrasonic Leak Detector Receiver

- Turn on the Receiver and plug the headphones into the jack located on the front of the Receiver. Any standard set of 3.5 mm jack headphones are compatible.
- Before moving to the target area, press "+" or "-" sensitivity buttons to adjust signal strength sensitivity to the highest possible level where bargraph still shows either 0 or a value close to 0. If signal strength cannot be adjusted down and the LCD still shows a maximum value regardless on sensitivity adjustments, press the Filter button.\*
- Scan the target area with the microphone sensor.

#### Note:

- For surroundings with a high level of background noise use the Power Parabola to direct the ultrasound towards the sensor.
- For locations that you cannot point the Receiver directly at the leak, the Probe Extension can be used (with the Flexible Probe).

### EUS-720-R Filter Operation

- In some situations, there might be strong ultrasonic noise generated by running machinery, motion sensors or other equipment. This noise will cause the Receiver to read the maximum signal strength on the display regardless of the sensitivity settings and make it unusable for detecting leaks.
- In such cases, press the "Filter" button. The firmware will automatically detect the main noise frequency and filter it out by applying digital non-pass bandwidth filter within +/- 5 kHz. If the signal level does not decrease down close to 0, then the firmware will automatically repeat the process for other noise frequencies. Up to three frequencies can be filtered out automatically. The filter icon will be displayed on the screen and will indicate the number of filters applied, from zero (no noise detected) to a maximum of three.

**Note :** The filter will be applied to the visual signal indication on a screen (signal strength number and bargraph). The filter will NOT be applied to the audio frequency in order to preserve original sound of the leak and allow the user to better determine the source of the leak.

Note: When working with the Transmitter, make sure to apply the filter on the Receiver before the Transmitter is turned on, or in an area where the Transmitter signal can not be detected. Otherwise, the Transmitter signal frequency will be filtered out and Receiver will not be able to pick it up.

- As you move nearer to the source of the leak, vibration or electric discharge, the signal strength will increase. This will be indicated on a screen with increasing signal strength number and level of the bargraph.
- The bargraph is a relative measurement only, so when the signal strength reaches maximum, lower the sensitivity by pressing the "-" sensitivity button until the displayed signal strength is less than 75. Repeat this process until you have isolated the source of the ultrasound.
- The audible sound emitted via headphones will help to verify the source of the leak, for example hissing sound of the air leak versus ticking sound of the electric discharge. The Receiver screen alone will not provide an indication of the leak source.

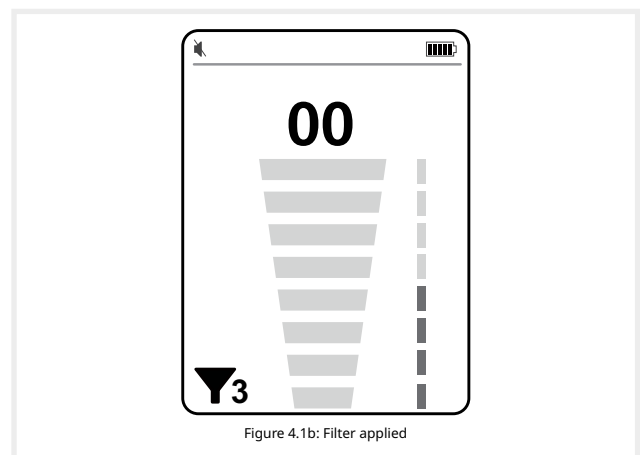
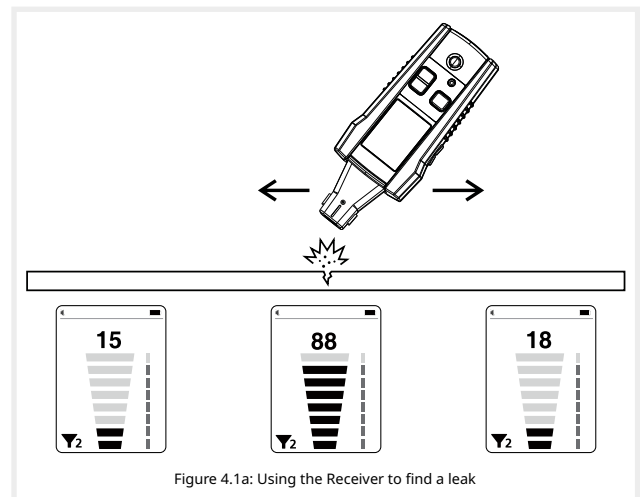

● **Using the EUS-730-T Ultrasonic Leak Detector Transmitter**

- The Transmitter allows for ultrasonic detection of openings in locations where there is no gas or air pressure, or the pressure is not sufficient to detect the leak with the Receiver alone.

Typical applications include verifying tightness or pinpointing places of air, water or gas leaks in:

- Fluid or gas tanks
- Building windows, doors or roofs
- Car windows and windshields
- HVAC vents
- Refrigerant pipelines

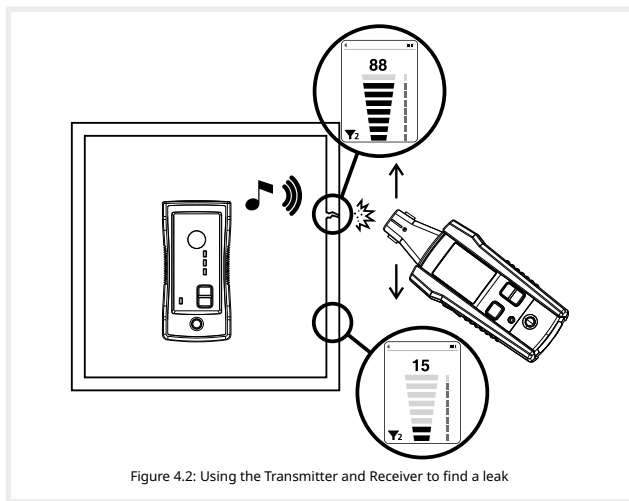

Figure 4.2: Using the Transmitter and Receiver to find a leak

- The process involves placing the Transmitter inside an object (such as tank, house or a car), sealing the entryways and scanning the object from the outside with the Receiver to verify tightness and pinpoint potential leaks.

1. Turn on the Transmitter.
2. Select the output signal level using the "+" or "-" signal level adjustment buttons.

Note: High setting is the default setting. For most applications and specifically for large objects this setting is particularly useful. The High signal may cause the Receiver to read maximum value away from the place of the leak even when lowest sensitivity was selected. Press "-" once to get to Medium signal and press "-" again to get to Low signal strength. Adjust signal level to allow for more precise pinpointing of the leaks.

3. Place the Transmitter inside the object to be verified and make sure entryways are sealed.
4. Perform leak detecting with the Receiver as described in section.

## Maintenance

● **Changing the Receiver Batteries**

- The EUS-720-R uses four 1.5 V AA (LR6) batteries (supplied). To replace the batteries, follow these steps:

- Make sure that the Receiver is turned off.
- Use a screw driver to unscrew the captive screw.
- Remove the battery cover.
- Replace the batteries as shown in Figure 5.1.

Observe the battery polarity shown in the battery compartment.

- Replace the battery cover and secure it with the provided screw.

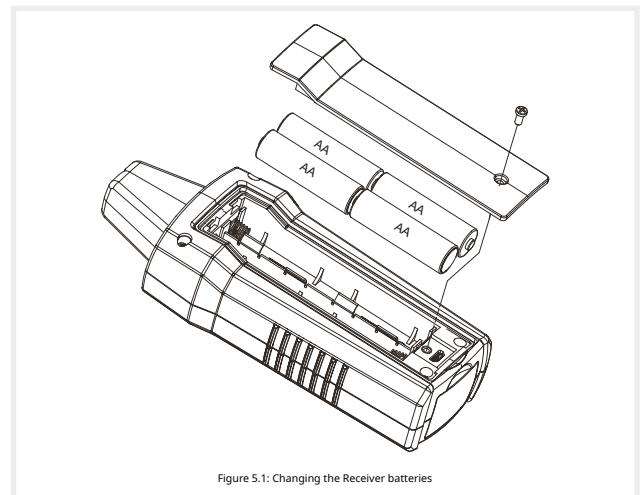

Figure 5.1: Changing the Receiver batteries



- **Changing the Transmitter Batteries**

- The EUS-720-T uses two 1.5 V AAA (LR03) batteries. To replace the batteries, follow these steps:
  - Make sure that the Transmitter is turned off.
  - Loosen the battery-door lock with a flat screwdriver.
  - Remove the battery cover.
  - Replace the batteries as shown in Figure 5.2. Observe the battery polarity shown in the battery compartment.
  - Replace the battery cover to the lock position.

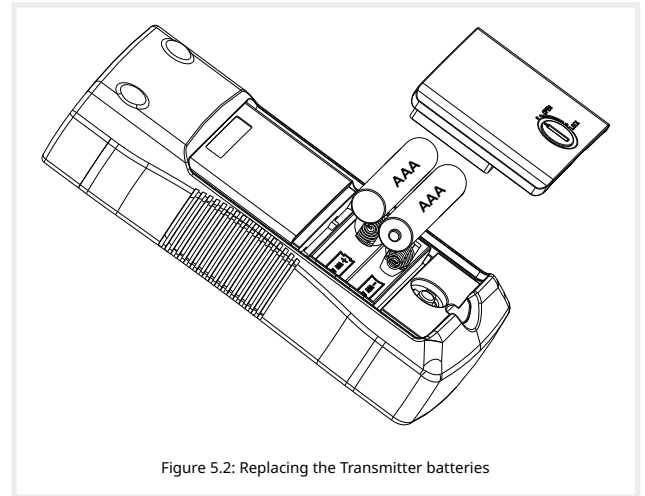



Figure 5.2: Replacing the Transmitter batteries

- **Cleaning**

- The only maintenance the EUS-720 requires is inspection and cleaning. Periodically wipe the exterior with a mild solution of detergent and water. Apply sparingly with a soft cloth and allow to dry completely before using. Do not use aromatic hydrocarbons, gasoline or chlorinated solvents for cleaning.

## Feature and Specifications

Features	WA-EUS-720 (Only Receiver)	WA-EUS-730 (Receiver + Transmitter)
Sensitivity Adjustment	Available	Available
Volume Adjustment	Available	Available
Signal Level Adjustment	Available	Available
Transmitter	Available	-
Earphone Jack (3.5 mm)	Available	Available
Display Size	LCD 2.5 in (6.35 cm)	LCD 2.5 in (6.35 cm)
Display Dimensions	1.45 x 1.93 in (36.72 x 48.96 mm)	1.45 x 1.93 in (36.72 x 48.96 mm)
Display Resolution	240(RGB) x 320 pixels	240(RGB) x 320 pixels
Display Type	TFT-LCD (262 K)	TFT-LCD (262 K)
Display Color	True, 16bit/color	True, 16bit/color
Frequency Range	20 kHz to 90 kHz	20 kHz to 90 kHz
Filter	±5 KHz of main noise frequency, upto three filters	±5 KHz of main noise frequency, upto three filters
Power Supply	4 x 1.5 V AA (LR6) alkaline batteries	4 x 1.5 V AA (LR6) alkaline batteries
Power Consumption (typical)	75 mA	75 mA
Battery Life (typical)	105 hours	105 hours
Low battery indication	Available	Available
Weight	0.518 lb (0.235 kg)	0.518 lb (0.235 kg)
Dimensions	7.547 x 2.984 x 1.791 in (183 x 75 x 43 mm)	7.547 x 2.984 x 1.791 in (183 x 75 x 43 mm)
APO function	60 minutes when in idle	
Operating Temperature	-20 °C to 50 °C	
Storage Temperature	-20 °C to 70 °C	
Operating Humidity	<80% RH	
Pollution Degree	2	
Protection	IP-40	
Certifications	 EN 61326-1	
Electromagnetic Compatibility (EMC)	Korea (KCC): Class A Equipment (Industrial Broadcasting & Communication Equipment) [1] Electromagnetic Compatibility (EMC) [1] This product meets requirements for industrial (Class A) electromagnetic wave equipment and the seller or user should take notice of it. This equipment is intended for use in business	

## Transmitter Specification

### Features

Frequency Range	Typical 40 kHz square wave
Power Supply	2x1.5V AAA (LR03) alkaline batteries
Power Consumption (typical)	33 mA
Battery Life (typical)	60 hours
Low battery indication	Red LED
Weight	Approx. 0.335 lb (0.152 kg)
Dimensions	5.295x2.559x1.326in (137x65 x33mm)

### Need Help ?

Contact your local dealer. Alternatively, contact **WiseAir Technologies**

- Call Us**  
 Asia : **+91 90477 78715**  
 Europe : **+45 36 99 04 22**
- Email Us**  
 Asia : **info@wiseair.asia**  
 Europe : **info@wiseair.asia**

# Understand Compressed Air System Dynamics with Our Advanced Measurement Solutions

Measure - Manage - Save - Sustain

## Our Network



### ASIA REGIONAL OFFICE

#### **WISEAIR TECHNOLOGIES INDIA LLP**

#12 Sri Venkatalakshmi Nagar,  
Singanallur, Coimbatore - 641 005. India  
Mob : +91 - 90477 78715  
Email : info@wiseair.asia

### CONTACT US

North America : info.usa@wiseair.eu  
Europe : info@wiseair.eu  
Middle East : info.uae@wiseair.eu  
South Asia : info@wiseair.in  
South East Asia : info@wiseair.asia



For More Info  
**SCAN HERE**

follow us @ wiseair.asia

